



C303

1 pole bi-directional DC and AC NO contactors
up to 1,500 volts and 500 amps

C303 - 1 pole bi-directional DC and AC NO contactors

With many years of experience and expertise in the development of electromechanical switching devices and mastery of direct current arcs, Schaltbau has developed an innovative solution with the new compact Eddicy C303 contactors, which further simplify applications in DC switching technology but are also suitable for classic AC applications.

The bi-directional DC and AC contactors of the C303 series are designed for operating voltages up to 1,500 volts and can carry currents of up to 500 amps continuously. Magnetic drives with three coil controls make the contactors versatile for use in modern industrial environments with ambient temperatures of up to 85 degrees. With a short-circuit switching capacity of up to 2,000 amps and a compact design, the C303 contactors are particularly suitable for applications that require high making currents or large capacities, but do not have space for large series. In the event of a short circuit, they can withstand 5,000 amps for 20 milli-

seconds without contact welding. This allows the contactor to retain its full functionality to disconnect high power independently of the current direction when required. This full bi-directionality is important for systems with energy recovery, i.e., for systems with a charging and discharging process, such as charging stations and ESS applications. Other typical applications include DC circuits in inverters, combiner boxes in photovoltaic systems, battery management for emission-free drive systems, and stationary applications for grid stabilization.

Features

Up to 25% reduction in energy costs for economical continuous operation

The newly developed main contacts have an extremely low contact resistance of typical 100 microohms. This permanently reduces contact heating, minimizes energy losses in the contactor, and significantly increases the efficiency of the main contact system. The low contact heating also means that less cooling is required. This leads to significantly reduced total cost of ownership (TCO).

Safe arc extinguishing - no risk of explosion

As a compact air contactor with permanent magnet arc extinguishing without gas encapsulation, the C303 compensates for overpressure. This ensures long, trouble-free operation in demanding environments.

V2G-ready for bi-directional charging stations

Bi-directional contactors are required for the perfect interaction between electric vehicles and charging stations. These enable electric vehicles not only to charge, but also to feed electricity into the grid or use it for the domestic power supply.

Optimal integration and performance thanks to magnetic drives

The C303 series is available with 3 coil controls: **Ecosave** drive with energy-saving PWM module for optimum power consumption during switching and low heating during holding, **High-Efficiency Drive (HED)** with optimized coil for maximum efficiency without PWM module or for external PWM control, and **Precharge** to limit high inrush currents of main contactors.

Full bi-directionality - reliable disconnection of high performances

All versions of the C303 can reliably switch high currents and voltages when required, regardless of the direction of current flow. These properties are achieved through the special arrangement of blow magnets and arcing chambers.

Mirror contact function for maximum operational reliability

The C303 contactors have an integrated auxiliary contact with mirror contact function according to IEC 60947-4-1, annex F. Mirror contacts are required in feedback circuits of safety controls. The mirror contact function informs about the switching state and ensures that the NC contact of the auxiliary contact is not closed at the same time as the NO main contact.

Applications

Applications for e-mobility

- DC fast charging stations
- Battery test benches for the automotive industry
- Battery management for emission-free drive systems, including in maritime applications (onshore and offshore)

Stationary applications

- Grid stabilization and battery energy storage
- Regenerative systems in industrial plants
- Battery management systems
- Uninterruptable Power Supplies (UPS)
- Photovoltaics

Ordering key

C303-350-G0P-24I-V1-P00		Special variant
Series, configuration	C303 1 pole DC NO contactor, Rated operational voltage $U_e = 1,500\text{ V}$	Ecosave [w/o] High-Efficiency Drive [w/o] external PWM control, w/o PWM module P00
Conv. thermal current	250 $I_{th} = 250\text{ A}$; Festkontakt Kupfer 350 $I_{th} = 350\text{ A}$; Festkontakt Kupfer 500 $I_{th} = 500\text{ A}$; Festkontakt Kupfer, versilbert	Auxiliary switches, configuration w/o * V0 1x integrated auxiliary contact SPDT with mirror contact function to IEC 60947-4-1, annex F V1
Assembly	G Mounting holes	Coil voltage/coil control (monostable) Ecosave: 12 ... 24 V DC, with PWM module 24I High-Efficiency Drive: 12 V DC, w/o PWM module 12H High-Efficiency Drive: 24 V DC, w/o PWM module 24H Precharge: 12 V DC, w/o PWM module (special variant P00) 12I Precharge: 24 V DC, w/o PWM module (special variant P00) 24I
Design fixed contacts	0 M6 connection	
Connector coil and aux. switch	P 5 pole connector, Phoenix Contact MCV 1.5/5-G-3.5-RN F 2x Flat tab 4.8 x 0.5 mm, High-Efficiency Drive and special variant P00 only *	

* Special design, on request

Accessories

5-pin connector for connecting the coil and auxiliary switch:
Anytek KD0510520000G or Phoenix Contact FMC 1,5/ 5-ST-3,5-RF,
please order separately.

Note: Presented in this catalogue are only stock items which can be supplied in short delivery time. For some variants minimum quantities apply. Please do not hesitate to ask for the conditions.

Special variants: If you need a special variant of the contactor, please do not hesitate to contact us. Maybe the type of contactor you are looking for is among our many special designs. If not, we can also supply customized designs. In this case, however, minimum order quantities apply.

Standards

IEC 60947-4-1

Low-voltage switchgear and controlgear – Part 4-1: Contactors and motor starters – Electromechanical contactors and motor starters

UL 60947-4-1

Low-Voltage Switchgear and Controlgear – Part 4-1: Contactors and Motor-Starters – Electromechanical Contactors and Motor-Starters.

GB/T 14048.4

Low-Voltage Switchgear and Controlgear – Part 4-1: Contactors and Motor-Starters – Electromechanical Contactors and Motor-Starters.

**C303 - Ecosave version:
Magnetic drive with energy-
saving PWM module with/
without auxiliary contact and
5-pin connector**

Main contact system with arc chamber

- 1-pole NO contact system
- Switching voltage 1,500 V max.
- Continuous current 500 A / 350 A / 250 A
- Highly efficient arc chamber with permanent magnetic blow-out

Electronic coil controller

Permanently reliable switching behaviour regardless of ambient temperature, reduced energy consumption and less heat generation.

Auxiliary switch

CO (SPDT) with mirror contact function according to IEC 60947-4-1, annex F

Fixed contacts main contact system

- Material: Copper
- Surface: C303-500 silver-plated
C303-350
C303-250
- Connection: M6, screw-in depth 8 ... 10 mm
- Busbar width: 14 mm min.

5-pin connector Auxiliary switch / coil

i Mating connector: A 5-pin connector is required to connect the coil and auxiliary switch, see page 10.

Main contact system with arc chamber

- 1-pole NO contact system
- Switching voltage 1,500 V max.
- Continuous current 500 A / 350 A / 250 A
- Highly efficient arc chamber with permanent magnetic blow-out

Electronic coil controller

Permanently reliable switching behaviour regardless of ambient temperature, reduced energy consumption and less heat generation.

Fixed contacts main contact system

- Material: Copper
- Surface: C303-500 silver-plated
C303-350
C303-250
- Connection: M6, screw-in depth 8 ... 10 mm
- Busbar width 14 mm min.

5-pin connector coil

i Mating connector: A 5-pin connector is required to connect the coil and auxiliary switch, see page 10.

Dimension diagram - version with PWM module, auxiliary contact and 5-pin connector

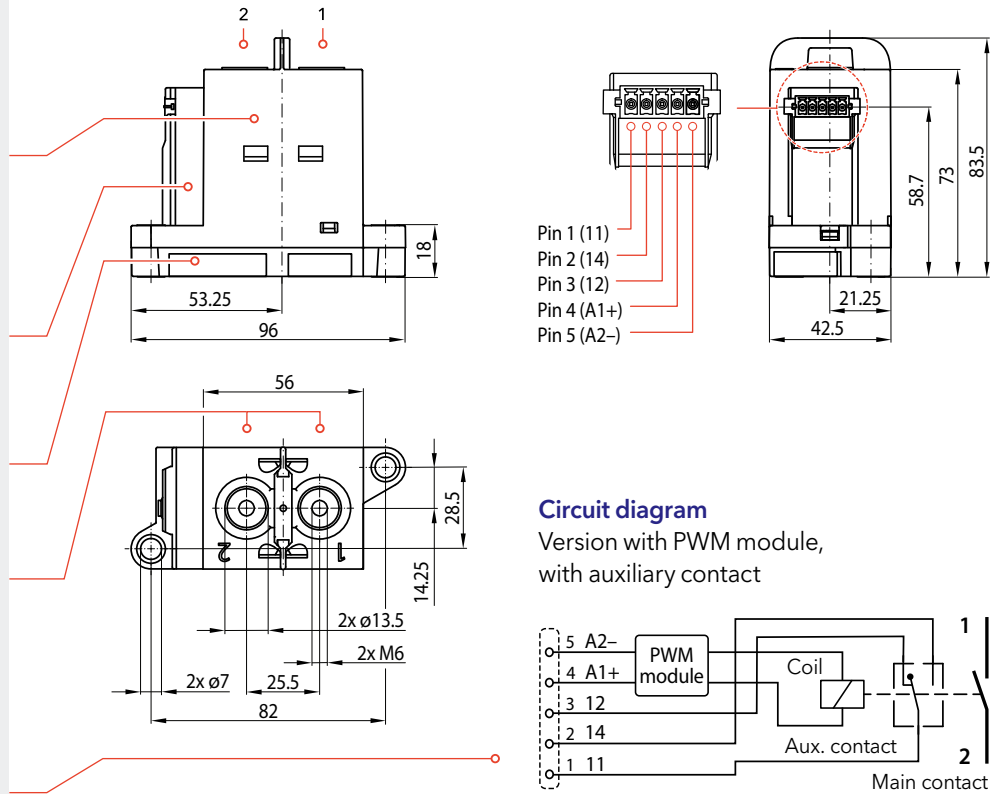

Circuit diagram

Version with PWM module, with auxiliary contact

Dimension diagram - version with PWM module, w/o auxiliary contact and 5-pin connector

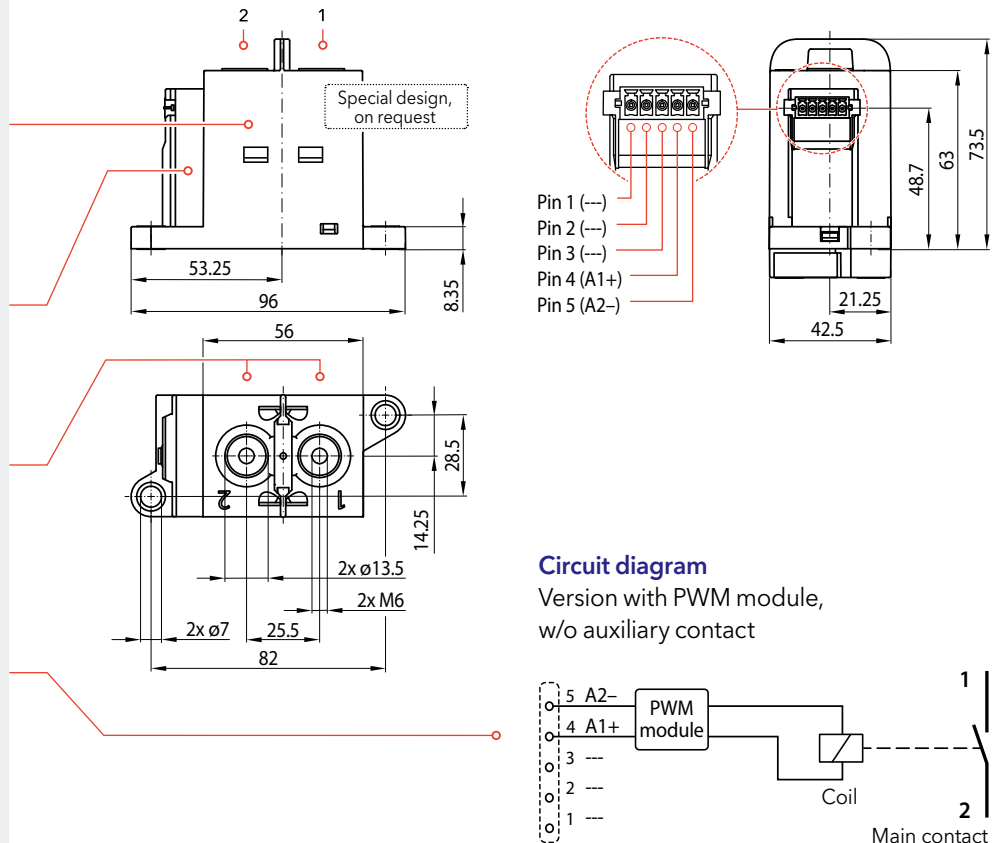

Circuit diagram

Version with PWM module, w/o auxiliary contact

Specifications - Ecosave with energy-saving PWM module

Series	C303-250	C303-350	C303-500
Type of voltage	DC bi-directional / AC (f ≤ 60 Hz)	DC bi-directional / AC (f ≤ 60 Hz)	DC bi-directional / AC (f ≤ 60 Hz)
Main contacts, configuration	1x, NO	1x, NO	1x, NO
Switching voltage max. U	1,500 V	1,500 V	1,500 V
Continuous current, recommended cross section *1	250 A @ 95 mm ²	350 A @ 120 mm ²	500 A @ 185 mm ²
Insulation resistance, new contacts	Main contact - ground	> 100 MΩ	> 100 MΩ
	Main contact - coil / aux. contact	> 100 MΩ	> 100 MΩ
	Main contact - main contact	> 100 MΩ	> 100 MΩ
Breaking capacity, L = 25 μH, bi-directional	Switching cycles	Switching cycles	Switching cycles
1 contactor in the circuit: 1 main contact	U _e = 1,500 V / I _e = 1,000 A	1	1
	U _e = 850 V / I _e = 2,200 A	1	1
	U _e = 850 V / I _e = 500 A	3	3
	U _e = 850 V / I _e = 350 A	10	10
	U _e = 450 V / I _e = 2,500 A	1	1
2 contactors in the circuit: series connection of 2 main contacts, switch-off simultaneously	U _e = 1,500 V / I _e = 2,200 A	1	1
	U _e = 1,500 V / I _e = 500 A	3	3
	U _e = 1,500 V / I _e = 350 A	10	10
	U _e = 850 V / I _e = 1,800 A	1	1
	U _e = 850 V / I _e = 1,200 A	5	5
Dielectric strength	Contact to contact; contact to coil; contact to aux (leakage current < 1 mA)	6,000 VAC 60 sec	6,000 VAC 60 sec

Electrical data according to IEC/UL 60947-4-1

Rated operational voltage U _e	max.	1,000 V*1	1,000 V*1	1,000 V*1
Rated insulation voltage U _i		1,000 V @ PD3 / 1,500 V @ PD2	1,000 V @ PD3 / 1,500 V @ PD2	1,000 V @ PD3 / 1,500 V @ PD2
Rated impulse withstand voltage U _{imp}		10 kV	10 kV	10 kV
Pollution degree / Overvoltage category		PD2 or PD3, see U _i / OV3	PD2 or PD3, see U _i / OV3	PD2 or PD3, see U _i / OV3
Conventional free air thermal current I _{th} *2	@ cross section	250 A @ 120 mm ²	350 A @ 185 mm ²	500 A @ 2x 150 mm ²
Power dissipation	@ I _{th} , typical	7 W	13 W	25 W
Pole impedance	new contacts, typical	100 μΩ	100 μΩ	100 μΩ
Frequency of operation (operations per hour) I _e	DC-1	360 h ⁻¹	360 h ⁻¹	360 h ⁻¹
Rated short-time withstand current I _{cw} (L < 50 μH)	@ t = 20 ms, typical	5,000 A*	5,000 A*	5,000 A*
	@ t < 5 ms, typical	15,000 A**	15,000 A**	15,000 A**
		* Contactor fully functional, no contact welding ** Contact welding, no detachment of conductive parts		
Rated short-circuit making capacity I _{cm}	L < 50 μH	2,000 A	2,000 A	2,000 A

Main contacts

Contact material	AgSnO ₂
Terminals	Thread M6
Torque	5 ... 6 Nm for screws with strength class 8.8

Auxiliary contacts

Number, configuration / contact material	1 CO (SPDT) / silver
Mirror contact function	IEC 60947-4-1, annex F ●
Utilisation category	AC-15: 60 VAC / 1.0 A DC-13: 60 VDC / 0.5 A
Minimum voltage / current	5 V / 5 mA
Terminals	5 pole connector

Magnetic drive with PWM module, monostable

Coil voltage U _s (operating range)*3	12 ... 24 V DC (9 ... 36 V DC)
Pollution degree / Overvoltage category	PD3 / OV2
Coil power, max.	Pull-in @ T _a = 20°C / 85°C
	42 W / 50 W
	Holding @ T _a = 20°C / 85°C
	2.8 W / 3.3 W
Pull-in time / drop-off time	@ T _a = 20°C / U _s , typical
	< 50 ms / < 5 ms
Coil suppression	PWM module with suppressor diode integrated
Coil terminal	5 pole connector

Mounting position

vertical / horizontal (see permissible mounting orientations on page 11)

Mechanical endurance

200,000 operations

Shock / Vibration

IEC 61373 Category 1, Class B

Operating temperature/Storage temperature -40°C ... +85°C / -40°C ... +95°C

Altitude/Humidity (EN 50125-1) < 4,000 m above sea level (1,000 V @ OV3, 1,500 V @ OV2) / < 75 % on an annual average

Approvals



Weight approx. 0.42 kg approx. 0.42 kg approx. 0.42 kg

*1 1,500 V max. for occasional switching

*2 In the application, the terminal temperature of the C303-250 max. 165°C, of the C303-350 max. 150°C or of the C303-500 max. 130°C must not be exceeded continuously.

*3 For a safe pull-in, the voltage must reach the lower value of the coil voltage U_s function range within a maximum of 1 ms.

C303 - High-efficiency drive version:
Efficient magnetic drive w/o PWM module, w/o auxiliary contact, 5-pin connector or flat tabs

Main contact system with arc chamber

- 1-pole NO contact system
- Switching voltage 1,500 V max.
- Continuous current 500 A / 350 A / 250 A
- Highly efficient arc chamber with permanent magnetic blow-out

Auxiliary switch

CO (SPDT) with mirror contact function according to IEC 60947-4-1, annex F

Fixed contacts main contact system

- Material: Copper
- Surface: C303-500 silver-plated
C303-350
C303-250
- Connection: M6, screw-in depth 8 ... 10 mm
- Busbar width 14 mm min.

5-pin connector Auxiliary switch / coil

i Mating connector: A 5-pin connector is required to connect the coil and auxiliary switch, see page 10.

Dimension diagram - version with auxiliary contact and 5-pin connector

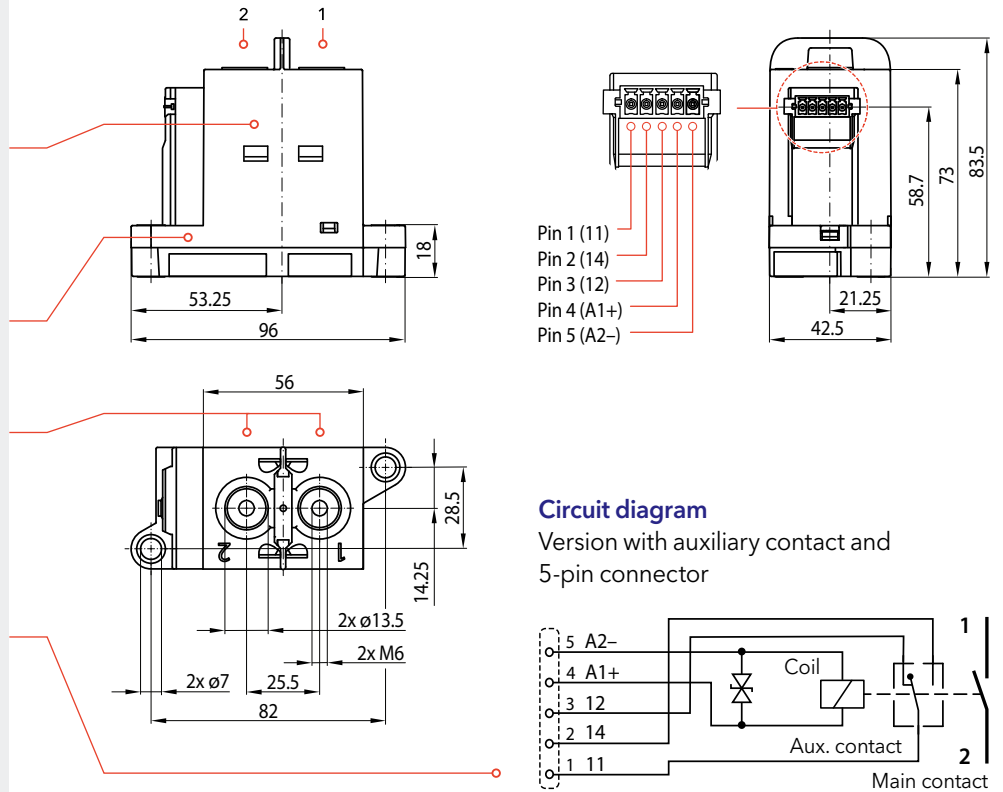

Circuit diagram

Version with auxiliary contact and 5-pin connector

Dimension diagram - version without auxiliary contact, with flat tabs

Main contact system with arc chamber

- 1-pole NO contact system
- Switching voltage 1,500 V max.
- Continuous current 500 A / 350 A / 250 A
- Highly efficient arc chamber with permanent magnetic blow-out

Coil connector

2x Flat tabs 4.8 x 0.5 mm

Fixed contacts main contact system

- Material: Copper
- Surface: C303-500 silver-plated
C303-350
C303-250
- Connection: M6, screw-in depth 8 ... 10 mm
- Busbar width 14 mm min.

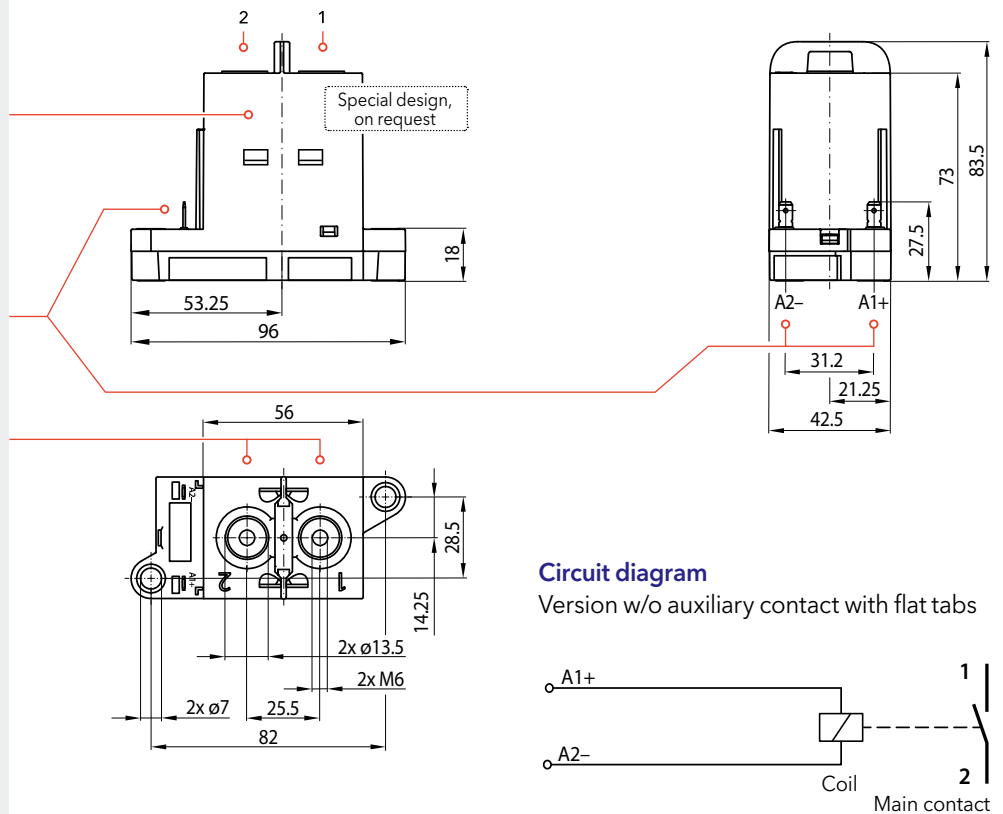

Circuit diagram

Version w/o auxiliary contact with flat tabs

Specifications - High-Efficiency Drive, w/o PWM module

Series	C303-250	C303-350	C303-500
Type of voltage	DC bi-directional / AC (f ≤ 60 Hz)	DC bi-directional / AC (f ≤ 60 Hz)	DC bi-directional / AC (f ≤ 60 Hz)
Main contacts, configuration	1x, NO	1x, NO	1x, NO
Switching voltage max. U	1,500 V	1,500 V	1,500 V
Continuous current, recommended cross section *1	250 A @ 95 mm ²	350 A @ 120 mm ²	500 A @ 185 mm ²
Insulation resistance, new contacts	Main contact - ground	> 100 MΩ	> 100 MΩ
	Main contact - coil / aux. contact	> 100 MΩ	> 100 MΩ
	Main contact - main contact	> 100 MΩ	> 100 MΩ
Breaking capacity, L = 25 μH, bi-directional	Switching cycles	Switching cycles	Switching cycles
1 contactor in the circuit: 1 main contact	U _e = 450 V / I _e = 1,000 A	2	2
	U _e = 850 V / I _e = 600 A	2	2
	U _e = 850 V / I _e = 200 A	50	50
2 contactors in the circuit: series connection of 2 main contacts, switch-off simultaneously	U _e = 450 V / I _e = 1,200 A	3	3
	U _e = 850 V / I _e = 1,000 A	5	5
Dielectric strength	Contact to contact; contact to coil; contact to aux (leakage current < 1 mA)	6,000 VAC 60 sec	6,000 VAC 60 sec

Electrical data according to IEC/UL 60947-4-1

Rated operational voltage U _e	max.	1,000 V*1	1,000 V*1	1,000 V*1
Rated insulation voltage U _i		1,000 V @ PD3 / 1,500 V @ PD2	1,000 V @ PD3 / 1,500 V @ PD2	1,000 V @ PD3 / 1,500 V @ PD2
Rated impulse withstand voltage U _{imp}		10 kV	10 kV	10 kV
Pollution degree / Overvoltage category		PD2 or PD3, see U _i / OV3	PD2 or PD3, see U _i / OV3	PD2 or PD3, see U _i / OV3
Conventional free air thermal current I _{th} *2	@ cross section	250 A @ 120 mm ²	350 A @ 185 mm ²	500 A @ 2x 150 mm ²
Power dissipation	@ I _{th} , typical	7 W	13 W	25 W
Pole impedance	new contacts, typical	100 μΩ	100 μΩ	100 μΩ
Frequency of operation (operations per hour) I _e	DC-1	360 h ⁻¹	360 h ⁻¹	360 h ⁻¹
Rated short-time withstand current I _{cw} (L < 50 μH)	@ t = 20 ms, typical @ t < 5 ms, typical	5,000 A* 15,000 A**	5,000 A* 15,000 A**	5,000 A* 15,000 A**
		* Contactor fully functional, no contact welding ** Contact welding, no detachment of conductive parts		
Rated short-circuit making capacity I _{cm}	L < 50 μH	2,000 A	2,000 A	2,000 A

Main contacts

Contact material	AgSnO ₂
Terminals	Thread M6
Torque	5 ... 6 Nm for screws with strength class 8.8

Auxiliary contacts

Number, configuration / contact material	1 CO (SPDT) / silver
Mirror contact function	IEC 60947-4-1, annex F ●
Utilisation category	AC-15: 60 VAC / 1.0 A DC-13: 60 VDC / 0.5 A
Minimum voltage / current	5 V / 5 mA
Terminals	5 pole connector

Magnetic drive, monostable

Coil voltage U _s (Operating range)	12 V DC (10.2 ... 13.8 V DC) or 24 V DC (20.4 ... 27.6 V DC)
Pollution degree / Overvoltage category	PD3 / OV2
Coil power, max. (T _a = 20 °C / U _s)	Cold coil / warm coil 9 W / 6 W
Pull-in time / drop-off time	@ T _a = 20 °C / U _s , typical < 50 ms / < 10 ms
Coil suppression	5 pole connector Suppressor diode Flat tabs ---
Coil terminal	5 pole connector or 2x flat tabs 4.8 x 0.5 mm

Mounting position

Vertical/horizontal (exception: do not mount upside down, see permissible mounting orientations on page 11)

Mechanical endurance

200,000 operations





Shock / Vibration

IEC 61373 Category 1, Class B

Operating temperature/Storage temperature -40° C ... +85° C / -40° C ... +95° C

Altitude/Humidity (EN 50125-1) < 4,000 m above sea level (1,000 V @ OV3, 1,500 V @ OV2) / < 75 % on an annual average

Approvals

Weight approx. 0.42 kg approx. 0.42 kg approx. 0.42 kg

*1 1,500 V max. for occasional switching

*2 In the application, the terminal temperature of the C303-250 max. 165° C, of the C303-350 max. 150° C or of the C303-500 max. 130° C must not be exceeded continuously.

C303 - Version for external PWM control or precharge without PWM module, with/without auxiliary contact, 5-pin connector or flat tabs

Main contact system with arc chamber

- 1-pole NO contact system
- Switching voltage 1,500 V max.
- Continuous current 500 A / 350 A / 250 A
- Highly efficient arc chamber with permanent magnetic blow-out

5-pin connector Auxiliary switch / coil

Auxiliary switch

CO (SPDT) with mirror contact function according to IEC 60947-4-1, annex F

5-pin connector coil

Fixed contacts main contact system

- Material: Copper
- Surface: C303-500 silver-plated
C303-350
C303-250
- Connection: M6, screw-in depth 8 ... 10 mm
- Busbar width 14 mm min.

i Mating connector: A 5-pin connector is required to connect the coil and auxiliary switch, see page 10.

Dimension diagram - version with/without auxiliary contact and 5-pin connector

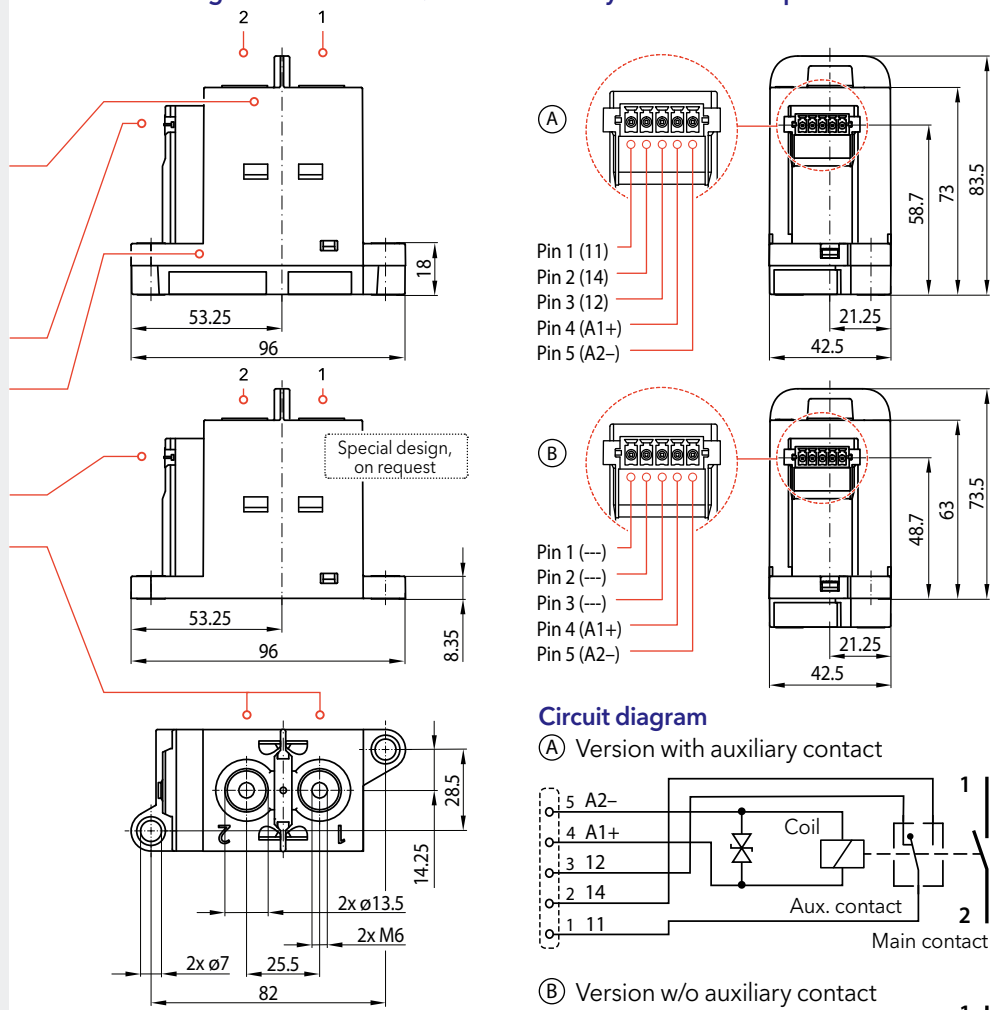

Dimension diagram - version without auxiliary contact, with flat tabs

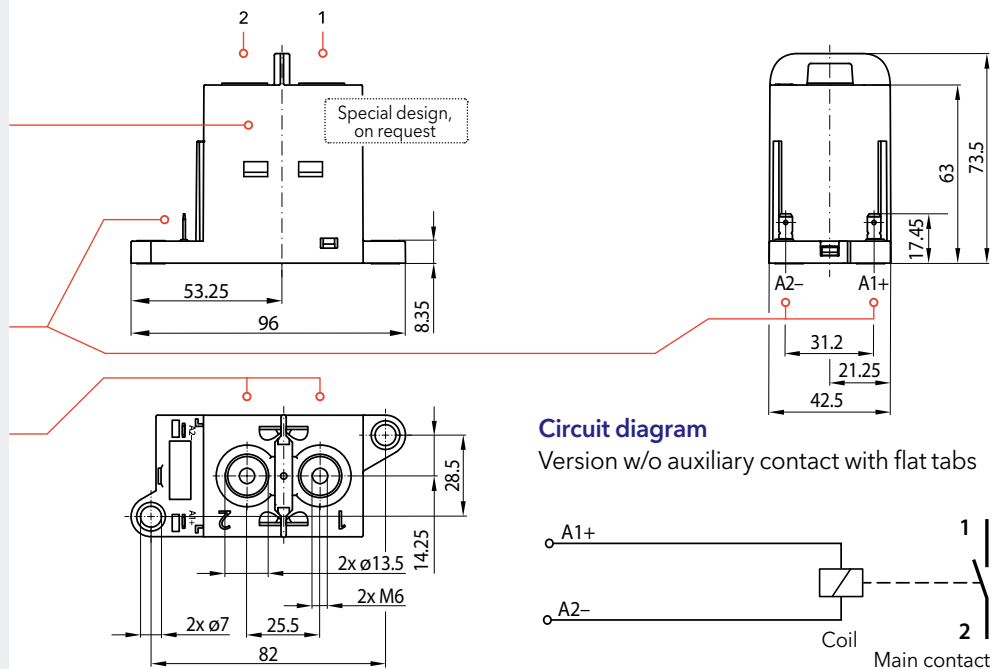

Main contact system with arc chamber

- 1-pole NO contact system
- Switching voltage 1,500 V max.
- Continuous current 500 A / 350 A / 250 A
- Highly efficient arc chamber with permanent magnetic blow-out

Coil connector

2x Flat tabs 4.8 x 0.5 mm

Fixed contacts main contact system

- Material: Copper
- Surface: C303-500 silver-plated
C303-350
C303-250
- Connection: M6, screw-in depth 8 ... 10 mm
- Busbar width 14 mm min.

Specifications - External PWM control or Precharge, w/o PWM module

Series	C303-250	C303-350	C303-500
Type of voltage	DC bi-directional / AC (f ≤ 60 Hz)	DC bi-directional / AC (f ≤ 60 Hz)	DC bi-directional / AC (f ≤ 60 Hz)
Main contacts, configuration	1x, NO	1x, NO	1x, NO
Switching voltage max. U	1,500 V	1,500 V	1,500 V
Continuous current, recommended cross section *1	250 A @ 95 mm ²	350 A @ 120 mm ²	500 A @ 185 mm ²
Insulation resistance, new contacts	Main contact - ground	> 100 MΩ	> 100 MΩ
	Main contact - coil / aux. contact	> 100 MΩ	> 100 MΩ
	Main contact - main contact	> 100 MΩ	> 100 MΩ
Breaking capacity, L = 25 μH, bi-directional	Switching cycles	Switching cycles	Switching cycles
	1 contactor in the circuit:		
	U _e = 1,500 V / I _e = 1,000 A	1	1
	U _e = 850 V / I _e = 2,200 A	1	1
	U _e = 850 V / I _e = 500 A	3	3
	U _e = 850 V / I _e = 350 A	10	10
	U _e = 450 V / I _e = 2,500 A	1	1
	U _e = 450 V / I _e = 1,200 A	5	5
	2 contactors in the circuit: series connection of 2 main contacts, switch-off simultaneously		
	U _e = 1,500 V / I _e = 2,200 A	1	1
U _e = 1,500 V / I _e = 500 A	3	3	
U _e = 1,500 V / I _e = 350 A	10	10	
U _e = 850 V / I _e = 1,800 A	1	1	
U _e = 850 V / I _e = 1,200 A	5	5	
U _e = 450 V / I _e = 2,500 A	1	1	
Dielectric strength	Contact to contact; contact to coil; contact to aux (leakage current < 1 mA)	6,000 VAC 60 sec	6,000 VAC 60 sec

Electrical data according to IEC/UL 60947-4-1

Rated operational voltage U _e	max.	1,000 V *1	1,000 V *1	1,000 V *1
Rated insulation voltage U _i		1,000 V @ PD3 / 1,500 V @ PD2	1,000 V @ PD3 / 1,500 V @ PD2	1,000 V @ PD3 / 1,500 V @ PD2
Rated impulse withstand voltage U _{imp}		10 kV	10 kV	10 kV
Pollution degree / Overvoltage category		PD2 or PD3, see U _i / OV3	PD2 or PD3, see U _i / OV3	PD2 or PD3, see U _i / OV3
Conventional free air thermal current I _{th} *2	@ cross section	250 A @ 120 mm ²	350 A @ 185 mm ²	500 A @ 2x 150 mm ²
Power dissipation	@ I _{th} , typical	7 W	13 W	25 W
Pole impedance	new contacts, typical	100 μΩ	100 μΩ	100 μΩ
Frequency of operation (operations per hour) I _e	DC-1	360 h ⁻¹	360 h ⁻¹	360 h ⁻¹
Rated short-time withstand current I _{cw} (L < 50 μH)	@ t = 20 ms, typical	5,000 A*	5,000 A*	5,000 A*
	@ t < 5 ms, typical	15,000 A**	15,000 A**	15,000 A**
		* Contactor fully functional, no contact welding ** Contact welding, no detachment of conductive parts		
Rated short-circuit making capacity I _{cm}	L < 50 μH	2,000 A	2,000 A	2,000 A

Main contacts

Contact material	AgSnO ₂
Terminals	Thread M6
Torque	5 ... 6 Nm for screws with strength class 8.8

Auxiliary contacts

Number, configuration / contact material	1 CO (SPDT) / silver
Mirror contact function	IEC 60947-4-1, annex F ●
Utilisation category	AC-15: 60 V AC / 1.0 A DC-13: 60 V DC / 0.5 A
Minimum voltage / current	5 V / 5 mA
Terminals	5 pole connector

Magnetic drive, monostable

Coil voltage U _s (Operating range) *3	12 V DC (10.2 ... 15 V DC) or 24 V DC (20.4 ... 30 V DC)
Pollution degree / Overvoltage category	PD3 / OV2
Coil power dissipation, max. (T _a = 20 °C / U _s)	30 W
Coil duty cycle	w/o PWM control: 30 %, duty cycle 30 sec max. external PWM control: Continuous operation, values available on request
Pull-in time (T _a = 20 °C / U _s) / Drop-off time (T _a = 20 °C / U _s)	typical < 50 ms / < 5 ms
Coil suppression	5 pole connector: Suppressor diode Flat tabs: ---
Coil terminal	5 pole connector or 2x flat tabs 4.8 x 0.5 mm

Mounting position

vertical / horizontal (see permissible mounting orientations on page 11)

Mechanical endurance

200,000 operations

Shock / Vibration

IEC 61373 Category 1, Class B

Environmental conditions

Operating temperature/Storage temperature: -40° C ... +85° C / -40° C ... +95° C
Altitude/Humidity (EN 50125-1): < 4,000 m above sea level (1,000 V @ OV3, 1,500 V @ OV2) / < 75 % on an annual average

Approvals



Weight

approx. 0.42 kg approx. 0.42 kg approx. 0.42 kg

*1 1,500 V max. for occasional switching

*2 In the application, the terminal temperature of the C303-250 max. 165° C, of the C303-350 max. 150° C or of the C303-500 max. 130° C must not be exceeded continuously.

*3 For a safe pull-in, the voltage must reach the lower value of the coil voltage U_s function range within a maximum of 1 ms.

Current-time diagram for C303

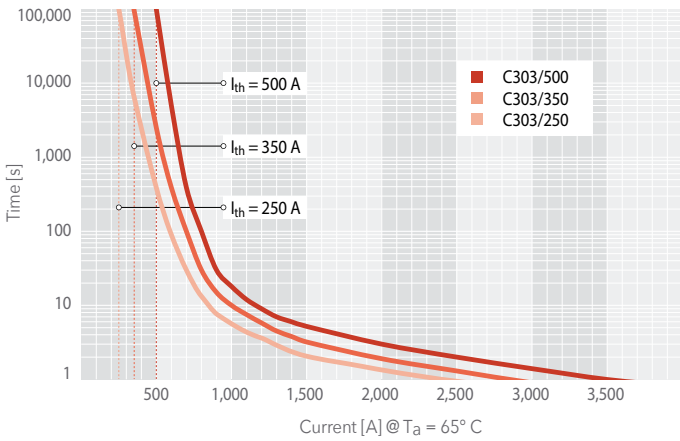

Current-electrical lifetime diagram C303 Ecosave/Precharge

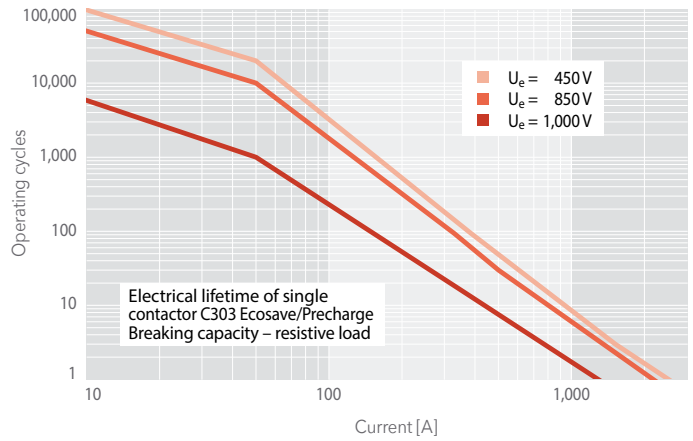

i Curves are extrapolated; contactor parameters and electrical lifetime vary depending on the application and conditions, e.g., load type, duty cycle, coil suppression, or environmental conditions.

Minimum distances

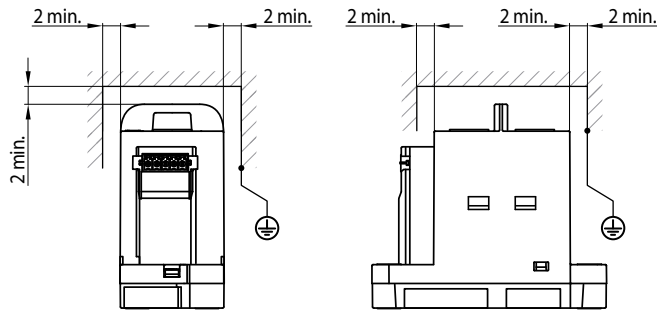

i For the C303 series, a minimum distance of 2 mm applies for short-circuit currents up to 8 kA to magnetically active, live, or earthed parts. Minimum distances for short-circuit currents greater than 8 kA are available on request.

Assembly of bus bars

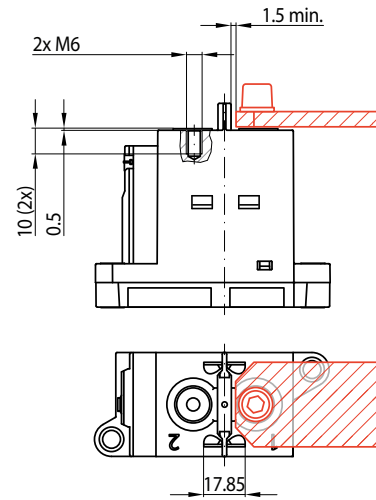

Minimum distance between insulating bar and busbar min. 1.5 mm

Busbar

Insulating plate

4x Overpressure openings
Leave openings free

2x M6 connecting screw, length 8 ... 10 mm + screw securing and thickness of the busbar; tightening torque 5 ... 6 Nm for screws with strength class 8.8

Mounting holes

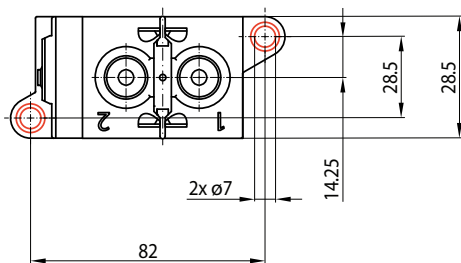

i The contactors are mounted on a suitable mounting plate using two M6 screws. Tightening torque: 6 ... 8 Nm for screws with strength class 8.8

5 pole connector for connecting of coil and auxiliary switch

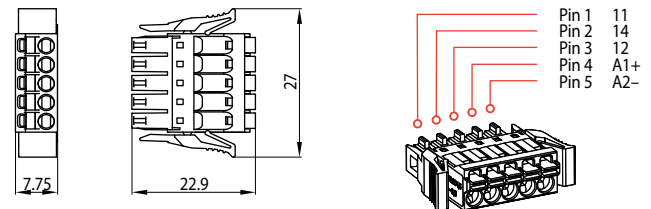

5 pole connector Anytek KD0510520000G or Phoenix Contact FMC 1.5/5-ST-3.5-RF

- Cross-section: 1.5 mm² max.
- Connection: Push-in spring connection
- Fastening type: Snap-in tabs

i Mating connector: An Anytek KD0510520000G connector is required to connect the coil and auxiliary switch. Please order separately.

Permissible mounting orientations

Ecosave, Precharge

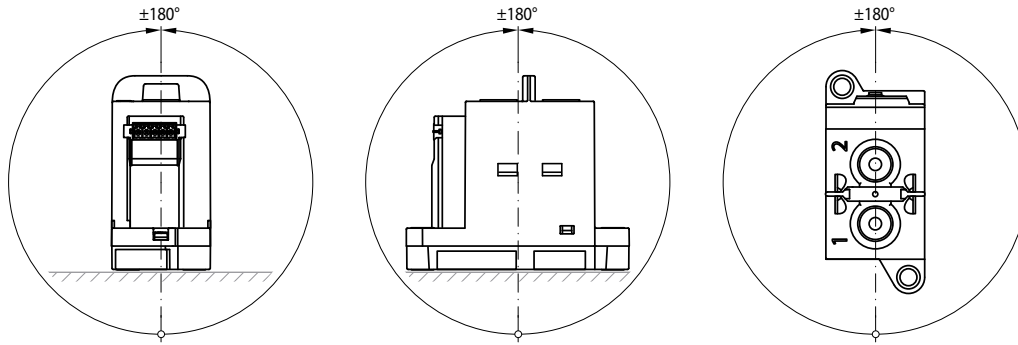

High-Efficiency Drive

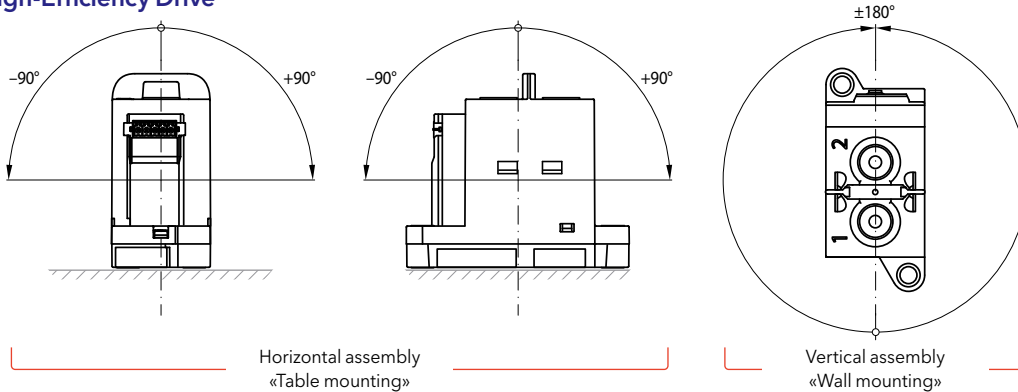

Maintenance and safety instructions

Maintenance:

- C303 series contactors are basically maintenance free.
- Make regular in-depth visual inspections once or twice a year.

Safety instructions:

- The device must be used according to the intended purpose as specified in the technical documentation. You are obliged to observe all specifications depending on operating temperature, degree of pollution etc. that are relevant to your application.
- Without further safety measures the contactors are not suited for use in potentially explosive atmospheres.
- In case of malfunction of the device or uncertainties stop using it any longer and contact the manufacturer instantly.
- Tampering with the device can seriously affect the safety of people and equipment. This is not permitted and leads to an exclusion of liability and warranty.
- Coil suppression for reducing surges when the coil is switched off is optimally attuned to the contactors switching behaviour. The existing opening characteristic must not be negatively influenced by parallel connection with an external diode.
- Contactors running permanently may heat up. So make sure that the contactor has sufficiently cooled down before you start any inspection or maintenance work.



For detailed maintenance, safety and mounting instructions please refer to our operating manuals > schaltbau.info/c303-m-en

- When installing contactors with magnetic blowout make sure to do it in such a way that no magnetizable parts can be attracted by the permanent magnets that are also capable of destroying all data of swipe cards.
- In general, strong electromagnetic fields can be generated in the area around the contactors. These can influence other components in the area of the contactors.
- Improper handling of the contactor, e.g. when hitting the floor with some impact, can result in breakage, visible cracks and deformation.



Defective contactors or parts (e.g. arc chambers, auxiliary switches) must be replaced immediately!



For a detailed list of all safety instructions see here: > schaltbau.info/safety3en/

We enable electrification for a sustainable future

Schaltbau is a global technology leader specializing in contactors, connectors, switches, and electrical devices.

As pioneers of electrification, Schaltbau has been championing safety on rail for generations. Building on nearly a century of rail experience, with our brand Eddicy we also create future-oriented products and solutions with the highest standards of safety and reliability to switch, connect, control and protect DC applications in energy and e-mobility.

Headquartered in Germany, Schaltbau has a worldwide presence with 12 production and sales sites on all major continents.

Find out more on www.schaltbau.com.