



INDICATIVE PRODUCT IMAGE

Product file

Type	Compact
Mounting	Wall
Code	BEWT352LA60P12
Range	BEWT
Version	Plug-in
Noise	42.3 dBA 10 m
Condensation	Air
Net weight	105 kg
PED	0
Defrost	Hot gas
Expansion	Valve
Application	LBP
Refrigerant	R290

Dimensions

Width L	711 mm
Depth P	1254 mm
Height H	828 mm

Absorptions

Power consumption	1800 W
Current consumption	3.3 A

Condenser

Fan-motors no.	1
Diameter	350 mm
Air flow	2540 m ³ /h

Unit cooler

Fan-motors no.	1
Diameter	350 mm
Air flow	2740 m ³ /h
Air throw	8 m

Compressor

Type	Hermetic
Compressors no.	2
Brand	EMBRACO
Voltage	400/3/50
Displacement	27.8 cm ³

Technical data - BEWT352LA60P12

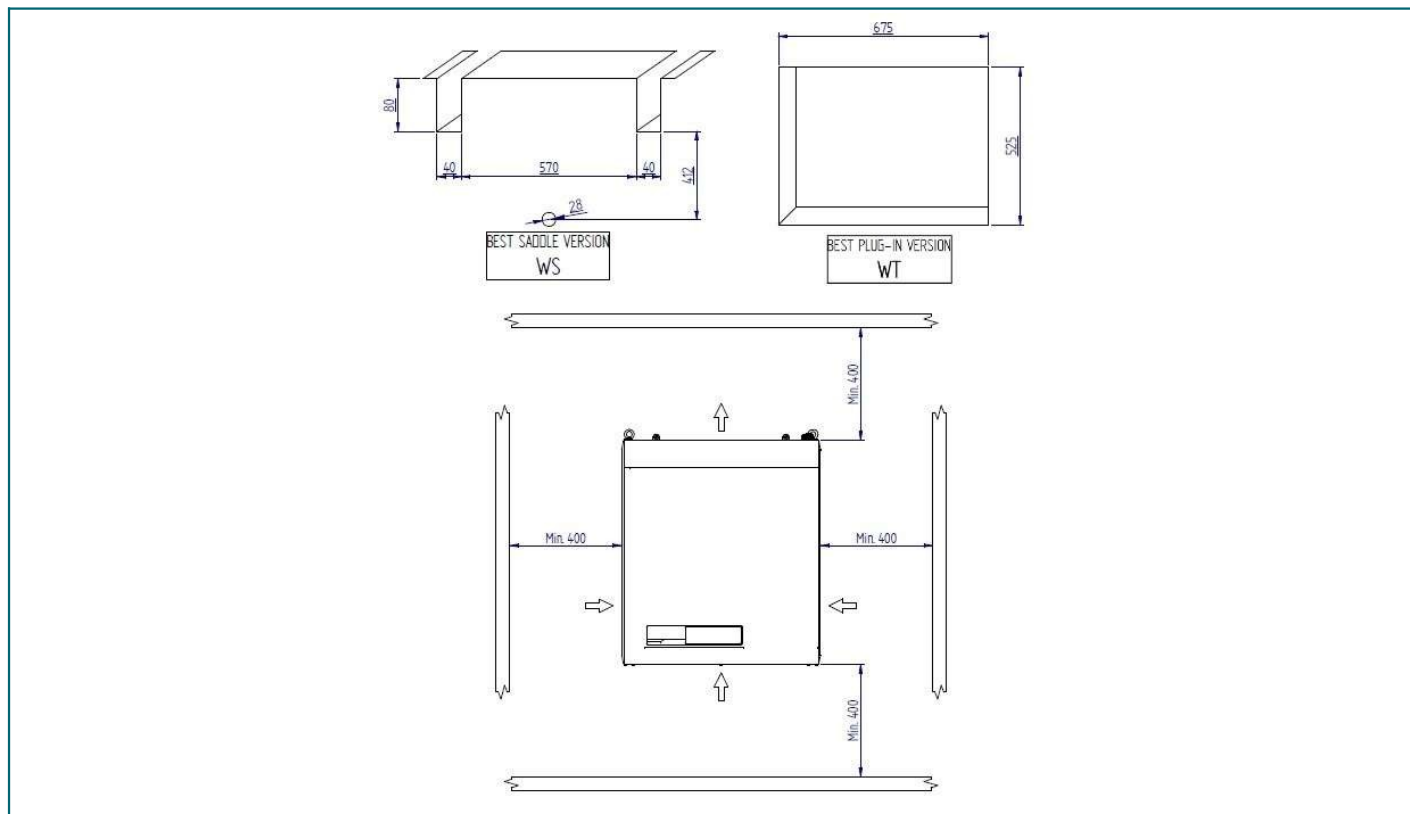

Technical data - BEWT352LA60P12

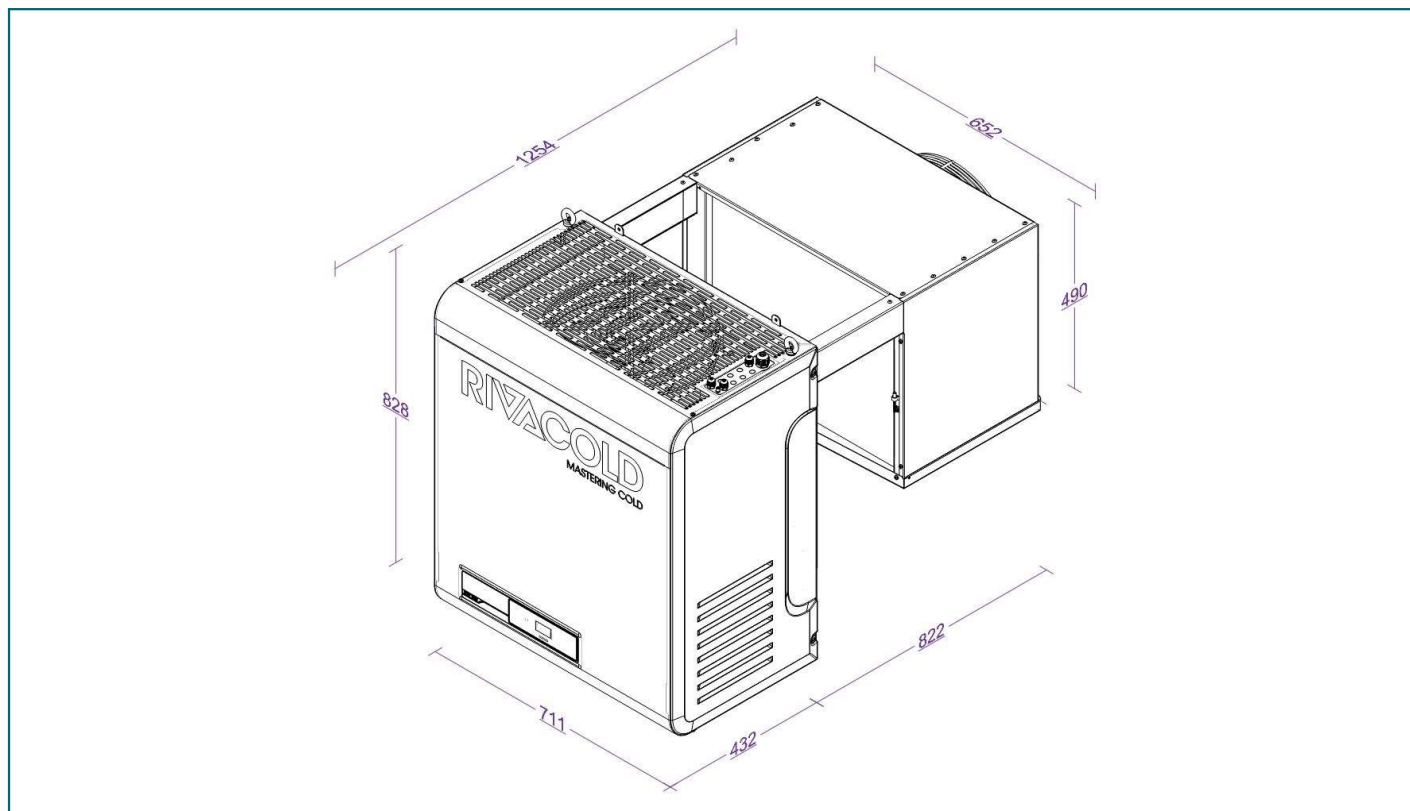

Refrigerating capacity table (W) - BEWT352LA60P12 - Refrigerant: R290

TA \ Cold room Temp	-25 °C	-20 °C	-15 °C
25 °C	1930 (25.6 m³)	2310 (40.8 m³)	2725 (65 m³)
32 °C	1802 (18.4 m³)	2161 (29.6 m³)	2553 (46.9 m³)
43 °C	1566 (9.2 m³)	1893 (15.7 m³)	2248 (25.8 m³)

Values referred to :

Suction gas : +20°C

Subcooling : 0K

Superheat : 100%

Compressor absorption :

Te -5°C (HBP); Tcond +50°C

Te -10°C (MBP); Tcond +50°C

Te -30°C (LBP); Tcond +50°C



INDICATIVE PRODUCT IMAGE

MAIN COMPONENTS MECHANICAL PART

- Hermetic compressors with thermal motor protection
- Condenser with Ø5mm tubes with internal spiral rifling
- Evaporator with Ø5/16" tubes with internal spiral rifling
- Electronic fan-motors on both condenser and evaporator
- Mechanical thermostat valve supplied standard across entire range
- Hot gas defrosting
- Evaporating water tray
- R290 refrigerant charge ≤ 150g per circuit

CONTROL CIRCUIT and ELECTRIC PART

- Safety pressure switch on high pressure side
- High and low pressure probes
- Door micro wired with cable L= 2.5
- Door heater cable on LT models (L = 2.5m)
- LED cold room light with cable L= 5m
- Power cable L= 2.5 m with wired electrical plug
- Industrial Plug (2P+E or 3P+N+E) 16 A
- Industrial Plug (2P+E) 32 A only on BEWx352MA80P11 and BEWx352LA60P11

ELECTRONIC CONTROL

- Riv-olution: programmable electronic control with software developed by Rivacold
- Smart Defrost and Leak Detector functions
- Bluetooth connectivity
- APP to manage and control packaged system functions
- Connection cable for BMS (RTU Modbus Protocol)
- LED display with new graphics and white backlight
- Backlit touch keyboard

STRUCTURE

- Self-supporting frame in galvanized metal sheet
- Easily removable housing to allow rapid access to the components in case of inspection or maintenance
- Installation kit complete with screws and washers to secure the packaged system to the wall of the coldroom and sealing putty in strips for insulation
- Plug-in thickness 100 mm for MT models and 150 mm for BT models (WT models)

OPTIONAL ITEMS

- Epoxy powder finish on all metal sheets
- Plug-in insulation kits supplied separately for saddle models (WS): 100mm, 150mm, 200mm
- Catephoresis treatment of exchangers (Condenser + Evaporator)
- Extension cable kits L=5m and L=10m (coldroom light cable, door heater cable, micro-switch cable)
- Remote control panel kits with 5m cable and 10m cable
- Presetting for Master & Slave (cable L=5m)
- Alarm cable kit L=5m
- IoT – Remote monitoring and control service (Wi-fi – 2G)