

Installation guide

EKE
Type EKE 100 (PV04)



080R0407

080R0407

Introduction

Superheat controller EKE 100 is for use where superheat must be accurately controlled or as driver for stepper motor valves typically in air conditioning, commercial and industrial heat pumps, commercial refrigeration, food retail and industrial application.

Compatible valves: ETS 6 / ETS 5M (Bipolar) / ETS 5T (Bipolar) / ETS 8M (Bipolar)/ETS C/KVS C/ ETS L/ETS 500-1000P/ CCMT L/CCMT/CCM/CTR / ICFL20

Basic application

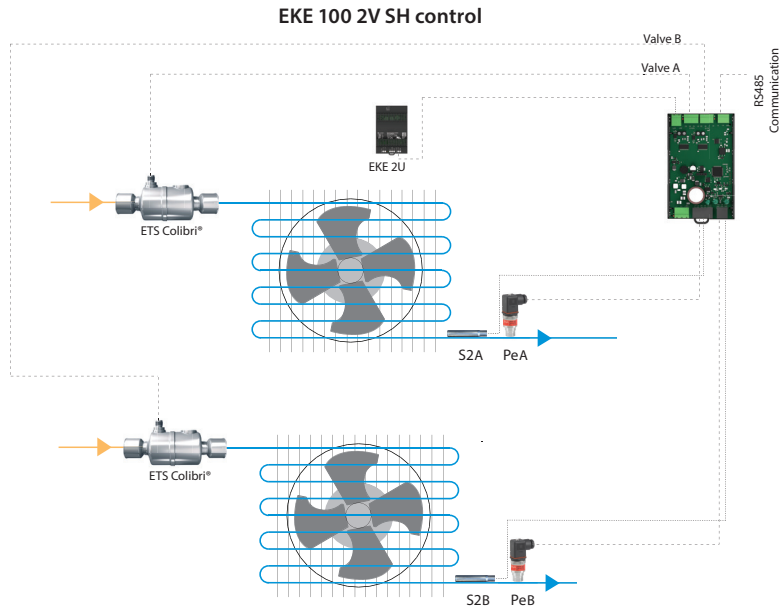
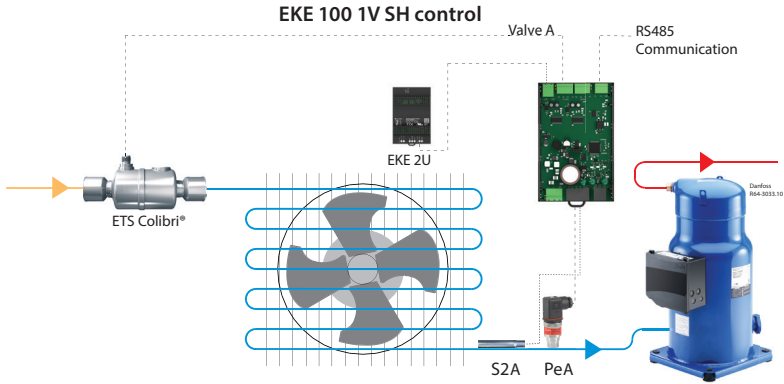

Імпортер: ТОВ з іл "Данфосс ТОВ" 04080, Київ 80, п/с 168, Україна

Info for UK customers only: Danfoss Ltd., 22 Wycombe End, HP9 1NB, GB

Dimension

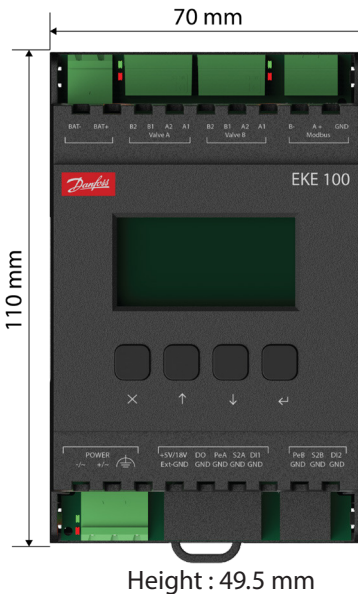
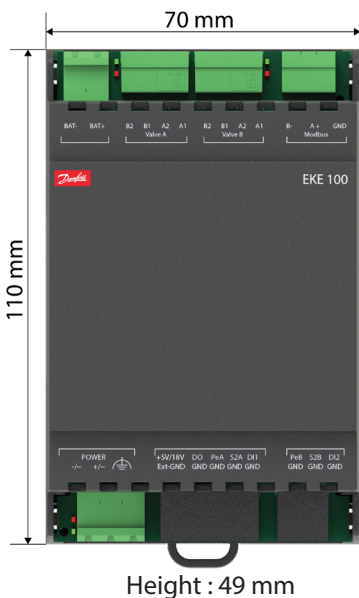
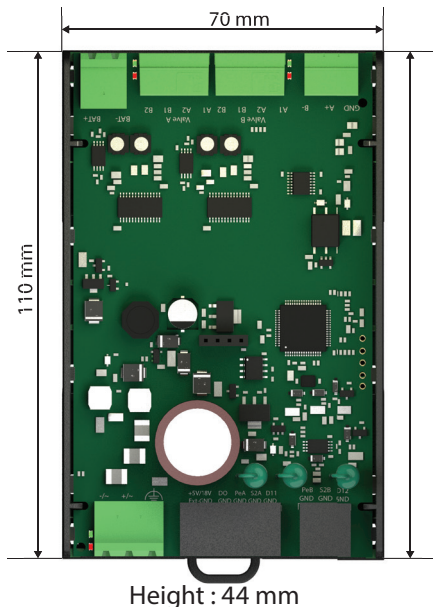

Technical specification

	EKE100 1V	EKE100 2V
Code number	IP00: 080G5050 IP20: 080G5051 IP20 + display: 080G5052	IP00: 080G5055 IP20: 080G5056 IP20 + display: 080G5057
Supply Voltage	24 V AC/DC* 50/60 Hz, SELV **	24 V AC/DC* 50/60 Hz, SELV **
Battery backup Input (Danfoss recommends EKE 2U)	24V DC	24V DC
Number of valve outputs	1 stepper motor valve	2 stepper motor valves
Valve type	Bipolar stepper valve	Bipolar stepper valve
Modbus RS485 RTU	Yes (Isolated)	Yes (Isolated)
Baud rate (default setting) ***	19200	19200
Mode (default setting) ***	8E1	8E1
No of temperature sensors	1 (S2A)	2 (S2A,S2B)
Type of temperature sensors	PT 1000/NTC 10K	PT 1000/NTC 10K
No of Pressure transmitter	1 (PeA)	2 (PeA,PeB)
Type of pressure transmitter	Ratiometric 0.5 - 4.5 V DC, 0-10 V Current 4-20 mA	Ratiometric 0.5 - 4.5 V DC, 0-10 V Current 4-20 mA
No of digital input	1 (DI1)	2 (DI1,DI2)
Use of digital input (software selectable)	Start/Stop regulation Heat/Cool mode Battery backup signal (SOH)	Start/Stop regulation Heat/Cool mode Battery backup signal (SOH)
Digital output	1 output: D0 (open collector), max sink current 10 mA	1 output: D0 (open collector), max sink current 10 mA
PC suite	KoolProg	KoolProg
Service Tools	EKA 200 + EKE 100 service cable	EKA 200 + EKE 100 service cable
Mounting (DIN rail)	35 mm DIN rail	35 mm DIN rail
Storage temperature	-30 – 80 °C / -22 – 176 °F	-30 – 80 °C / -22 – 176 °F
Operating temperature	-20 – 70 °C / -4 – 158 °F	-20 – 70 °C / -4 – 158 °F
Humidity	<90% RH, non-condensing	<90% RH, non-condensing
Enclosure	Available in IP00, IP20 and IP20 with integrated display.	Available in IP00, IP20 and IP20 with integrated display.



Note:

* The unit is suitable for use on a circuit capable of delivering not more than 50A RMS symmetrical Amperes

** For US and Canada, use class 2 power supply

*** Values mentioned are for standard variants

Connection Overview

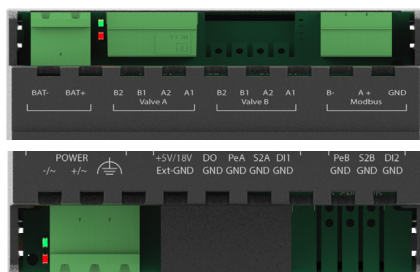

EKE 100 1V

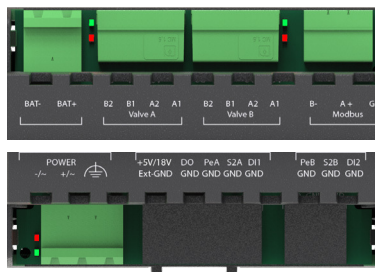

EKE 100 2V

Port	Description
- / ~ and + / ~	Power supply
	Functional Earth
+ 5 V / 18 V	Voltage for pressure probe **
+ 5 V / 18 V	Voltage for pressure probe **
Ext-GND	Ground for driver signal input
GND	Ground/Comm for I/O signals
DO	Digital Output
PeA	Pressure signal for A circuit/ Driver analog signal for A circuit
S2A	Temperature signal for A circuit
DI1*	Digital Input for A circuit
PeB	Pressure signal for B circuit/ Driver analog signal for B circuit
S2B	Temperature signal for B circuit
DI2	Digital Input for B circuit
BAT - and BAT +	Battery backup inputs
Valve A	Valve port for circuit A
Valve B	Valve port for circuit B
MODBUS (B-, A+, GND)	Modbus port

⚠ Note:

* DI is software configurable, If not using with external signal, then short circuit it or configure it as not used in software.

** By default the power supply for pressure transmitter is set for 0V. Supply will change to 5V if pressure transmitter is selected as ratiometric and 18V if selected as current type. Supply can be changed manual by selecting it in parameter P014 in advanced I/O configuration. When using 2 valve model both terminals will always supply the same voltage.

See below table with recommended connection terminals for driver function

Driver input	Terminal to use - signal Input A	Terminal to use - signal Input B
Voltage A / Voltage B	Ext. GND + PeA	Ext. GND + PeB
Current A / Current B	GND + PeA	GND + PeB
Voltage A / Current B	GND + PeA	GND + PeB
Current A / Voltage B	GND + PeA	GND + PeB

Mounting/Demounting

The unit can be mounted onto a 35 mm DIN rail simply by snapping it into place and securing it with a stopper to prevent sliding. It is demounted by gently pulling the stirrup located in the base of the housing.

Mounting :

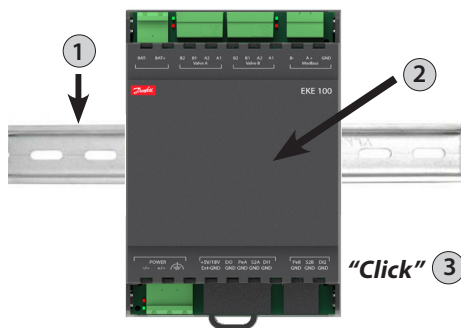

Demounting :

Step 1:

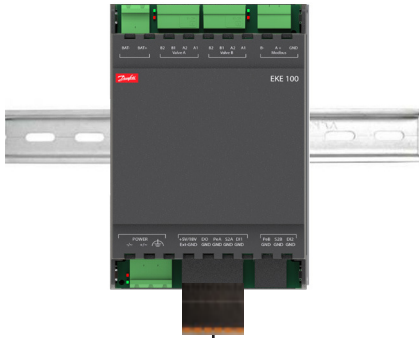

Unplug above shown male connector

Step 2:

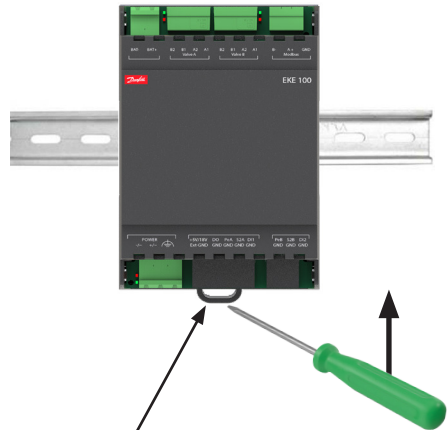

Pull stirrup using screwdriver and remove EKE from rail

General guide: Sensor installation

Sensor mounting: Temperature sensor

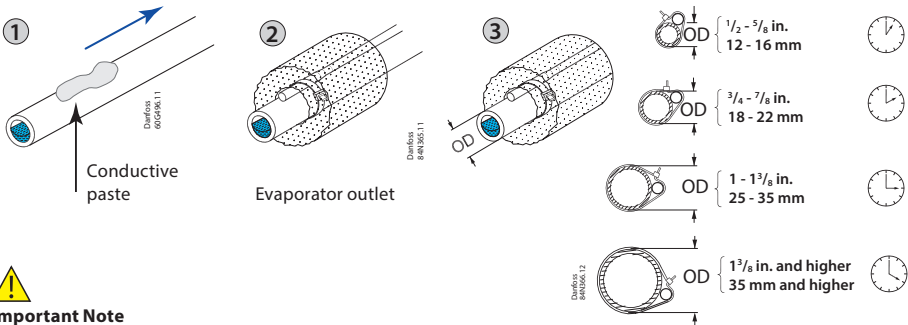

Important Note

- Mount the sensor on a clean paint-free surface.
- Remember to use heat conducting paste and insulate the sensor.
- For precise measurements, mount the sensor max. 5 cm from the outlet of the evaporator.

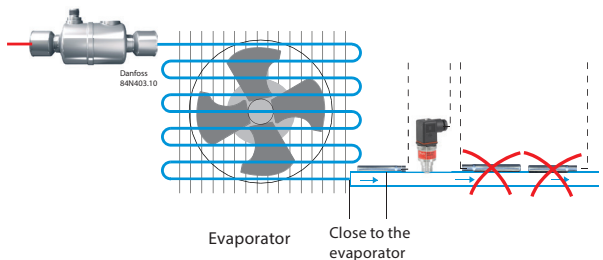

Modbus installation

- For the Modbus cable, it is best to use 24 AWG shielded twisted-pair cable with a shunt capacitance of 16 pF/ft and 100 Ω impedance.
- The controller provides an insulated RS485 communication interface which is connected to the RS485 terminals (see connection overview).
- The max. permissible number of devices simultaneously connected to RS485 cable output is 32.
- The RS485 cable is of impedance 120 Ω with maximum length of 1000 m.
- Terminal resistors 120 Ω for terminal devices are recommended at both ends.
- The EKE communication frequency (baud rate) can be one of the following: 9600, 19200 or 38400 baud, default 19200 8E1.
- The default unit address is 1.
- For detailed info on Modbus PNU, check EKE 100 manuals

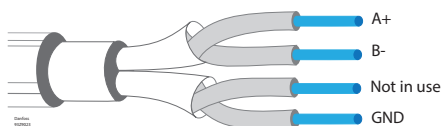

Manual resetting Modbus address:

1. Ensure pressure transmitter settings is set to ratiometric type transmitter in configuration.
2. Remove Supply power from EKE 100
3. Connect terminal BAT+ to +5 V / 18 V (Important to make sure step 1 is observed)
4. Connect EKE 100 to power
5. Now Modbus communication options are reset to factory default (Address 1, 19200 baud, mode 8E1)

Signal Sharing

Power and backup supply sharing

- 1 EKE 100 and 1 EKE 2U can share power supply(AC or DC)
- 2 EKE 100 and 1 EKE 2U can share power supply only with DC

Pressure sensor sharing

- Physical sharing is allowed if used within the same controller and not allowed if 2 or more controllers are used for sharing.
- Modbus sharing is allowed with more than 1 controller.
- Software sharing is allowed within one controller by selecting option Common.

Temperature sensor sharing

- Physical sharing is not allowed.
- Modbus sharing is allowed with more than 1 controller.
- Software sharing is allowed within one controller by selecting option Common.

Cabling

Stepper valve connector	ETS/KVS/CCM/ CCMT/CTR/ CCMT L (Using Danfoss M12 Cable)	ETS 8M Bipolar / ICFL20	ETS 6	ETS 5M / 5T Bipolar
A1	White	Orange	Orange	Orange
A2	Black	Yellow	Yellow	Yellow
B1	Red	Red	Red	Red
B2	Green	Black	Black	Black
Not connected	-	-	Grey	-



- All valves are driven in a bipolar mode with a 24 V supply chopped to control the current (Current driver).
- The stepper motor is connected to the “Stepper Valve” terminals (see terminal assignment) with a standard M12 connection cable.
- To configure stepper motor valves other than Danfoss stepper motor valves, the correct valve parameters must be set as described in the Valve configuration section by selecting user defined valve.

	Cable length	Wire size min/max (mm ²)
Power supply and Battery input	Max 5m	AWG 24-12 (0.34-2.5 mm ²) Torque (0.5-0.56 Nm)
Analog inputs	Max 10m	AWG 24-16 (0.14-1.5 mm ²)
Sensor	Max 10m	AWG 24-16 (0.14-1.5 mm ²)
Stepper valve	Max 30m	AWG 24-16 (0.14-1.5 mm ²) Torque (0.22-0.25 Nm)
Digital input	Max 10m	AWG 24-16 (0.14-1.5 mm ²)
Digital output	Max 10m	AWG 24-16 (0.14-1.5 mm ²)



- The max. cable distance between the controller and the valve depends on many factors like shielded/unshielded cable, the wire size used in the cable, the output power for the controller and the EMC.
- Keep controller and sensor wiring well separated from mains wiring.
- Connecting sensor wires more than specified length may decrease the accuracy of measured values.
- Separate the sensor and digital input cables as much as possible(at least 10 cm) from the power cables to the loads to avoid possible electromagnetic disturbances. Never lay power cables and probe cables in the same conduit (including those in electrical panels)

LED Alarm and Warning

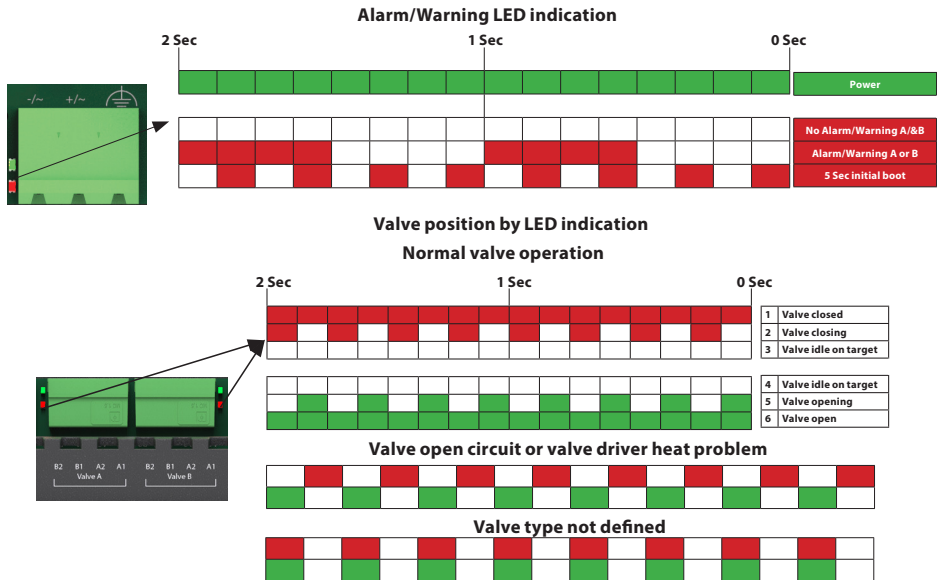

Display Structure

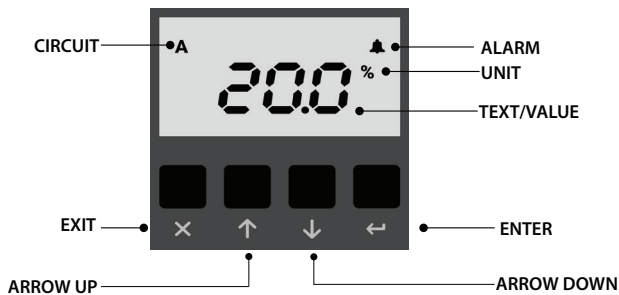

General features and warning

Plastic housing features

- DIN rail mounting complying with EN 60715
- Self-extinguishing V0 according to IEC 60695-11-10 and glowing/hot wire test at 960 °C according to IEC 60695-2-12

Other features

- To be integrated in Class I appliances
- Index of protection: IP00 or IP20 on product, depending on sales number
- Period of electric stress across insulating parts: long - Suitable for using in pollution degree 2 environment

- Category of resistance to heat and fire: IEC/EN 60335-1, 30.2.1 and 30.2.3 of edition 5.2
- Immunity against voltage surges: category II
- Software class and structure: class A
- Type 1 control
- Overvoltage category III (Rated impulse voltage 800 V)

General warnings

- Every use that is not described in the manuals of EKE 100 is considered incorrect and is not authorized by the manufacturer
- Verify that the installation and operating conditions of the device respect those specified in the manuals, especially concerning the supply voltage and environmental conditions
- All service and maintenance operations must therefore be performed by qualified personnel
- The device must not be used as a safety device
- Liability for injury or damage caused by the incorrect use of the device lies solely with the user

Installation warnings

- Recommended mounting position: Din rail, Panel mounting
- Ensure that only trained and qualified personnel perform installation, start up, and maintenance.
- Ensure that electrical work conforms to national and local electrical codes, regulations and/or standards
- Before working on the electrical connections, disconnect the device from the main power supply
- Before carrying out any maintenance operations on the device, disconnect all electrical connections
- Do not expose the device to continuous water sprays or to a relative humidity greater than 90%.
- Do not exposure to corrosive or pollutant gases, natural elements, environments where explosives or mixes of flammable gases are present, dust, strong vibrations or shock, large and rapid fluctuations in ambient temperature that might cause condensation in combination with high humidity, strong magnetic and/or radio interference (e.g., transmitting antenna)
- Use cable ends suitable for the corresponding connectors. After tightening connector screws, tug the cables gently to check their tightness - Minimize the length of probe and digital input cables as much as possible, and avoid spiral routes around power devices. Separate from inductive loads and power cables to avoid possible electromagnetic noises
- Use appropriate data communication cables. Refer to above in present document.
- Minimize the length of probe and digital input cables as much as possible and avoid spiral routes around power devices. Separate from inductive loads and power cables to avoid possible electro magnetic noises
- Avoid touching or nearly touching the electronic components fitted on the board to avoid electrostatic discharges
- This product is not subject to the UK PSTI regulation, as it is for supply to and use only by professionals with the necessary expertise and qualifications. Any misuse or improper handling may result in unintended consequences. By purchasing or using this product, you acknowledge and accept the professional-use-only nature of its application. Danfoss does not assume any liability for damages, injuries, or adverse consequences ("damage") resulting from the incorrect or improper use of the product and you agree to indemnify Danfoss for any such damage resulting from your incorrect or improper use of the product.

Product warnings

- Connecting any EKE inputs to mains voltage will permanently damage the controller.
- Battery Backup terminals does not generate power to recharge a device connected.
- Battery backup - the voltage will close the stepper motor valves if the controller loses its supply voltage.
- Do not connect an external power supply to the digital input DI terminals to avoid damaging the controller.

Danfoss Related products		
<p style="text-align: center;">Powersupply</p>	<p style="text-align: center;">Temperature sensor</p>	<p style="text-align: center;">Pressure transducer</p>
		
<p>AK-PS Input: 100 – 240 V AC, 45 – 65 Hz Output: 24 V DC: available with 18 VA, 36 VA and 60 VA</p> <p>ACCTRD Input: 230 V AC, 50 – 60 Hz Output: 24 V AC, available with 12 VA, 22 VA and 35 VA</p>	<p>PT 1000 AKS is a High precision temp. sensor AKS 11 (preferred), AKS 12, AKS 21 ACCPBT PT1000</p> <p>NTC sensors EKS 221 (NTC-10 Kohm) MBT 153 ACCPBT NTC Temp probe (IP 67 /68)</p>	<p>DST / AKS Pressure Transducer Available with ratiometric and 4 – 20 mA.</p> <p>NSK Ratiometric pressure probe</p> <p>XSK Pressure probe 4 – 20 mA</p>
<p style="text-align: center;">Stepper motor valves</p>	<p style="text-align: center;">M12 cable</p>	<p style="text-align: center;">Backup power module</p>
		
<p>EKE is compatible with Danfoss stepper motor valves i.e Danfoss ETS 6, ETS, KVS, ETS Colibri®, KVS colibri®, CTR, CCMT, ETS 8M (Bipolar), CCMT L, ETS L</p>	<p>M12 Angle cable to connect Danfoss stepper motor valve and EKE controller</p>	<p>EKE 2U energy storage device for emergency valve shutdown during power outage.</p>
<p style="text-align: center;">EKA 200 Koolkey</p>	<p style="text-align: center;">EKE 100 service cable</p>	
		
<p>EKA 200 is used as a service/copy key for EKE 100 controller</p>	<p>EKE 100 service cable is used to connect EKE 100 controller to EKA 200 Koolkey</p>	

Any information, including, but not limited to information on selection of product, its application or use, product design, weight, dimensions, capacity or any other technical data in product manuals, catalogues descriptions, advertisements, etc. and whether made available in writing, orally, electronically, online or via download, shall be considered informative, and is only binding if and to the extent, explicit reference is made in a quotation or order confirmation. Danfoss cannot accept any responsibility for possible errors in catalogues, brochures, videos and other material. Danfoss reserves the right to alter its products without notice. This also applies to products ordered but not delivered provided that such alterations can be made without changes to form, fit or function of the product.

All trademarks in this material are property of Danfoss A/S or Danfoss group companies. Danfoss and the Danfoss logo are trademarks of Danfoss A/S. All rights reserved.